



US 20100283071A1

(19) **United States**

(12) **Patent Application Publication**  
**LI et al.**

(10) **Pub. No.: US 2010/0283071 A1**  
(43) **Pub. Date: Nov. 11, 2010**

(54) **ORGANIC ELECTROLUMINESCENT DISPLAY DEVICE AND METHOD OF MANUFACTURING THE SAME**

**Publication Classification**

(51) **Int. Cl.**  
*H01L 51/52* (2006.01)  
*H01L 33/00* (2010.01)  
(52) **U.S. Cl. ....** 257/98; 438/29; 257/40; 257/E51.018; 257/E33.061

(76) **Inventors:** **Fengjin LI**, Gumi-si (KR);  
**Jaeyoung Lee**, Chilgok-gun (KR);  
**Taeyeon Yoo**, Chilgok-gun (KR)

(57) **ABSTRACT**

A method of manufacturing an organic electroluminescent display device may comprise forming transistors on a substrate, forming a lower electrode over an insulating layer, forming an insulating layer on the transistors, the lower electrode being coupled to a source or a drain of each of the transistors, forming a bank layer on the lower electrode, the bank layer having openings to expose part of the lower electrode, forming a bus electrode on the bank layer, forming an organic light-emitting layer to cover the lower electrode, the bank layer, and the bus electrode, patterning the organic light-emitting layer using a laser, thereby exposing the bus electrode placed on the bank layer, and forming an upper electrode on the organic light-emitting layer so that the upper electrode comes into contact with the exposed bus electrode.

Correspondence Address:  
**BIRCH STEWART KOLASCH & BIRCH**  
**PO BOX 747**  
**FALLS CHURCH, VA 22040-0747 (US)**

(21) **Appl. No.:** 12/608,648

(22) **Filed:** Oct. 29, 2009

(30) **Foreign Application Priority Data**

May 6, 2009 (KR) ..... 10-2009-0039313

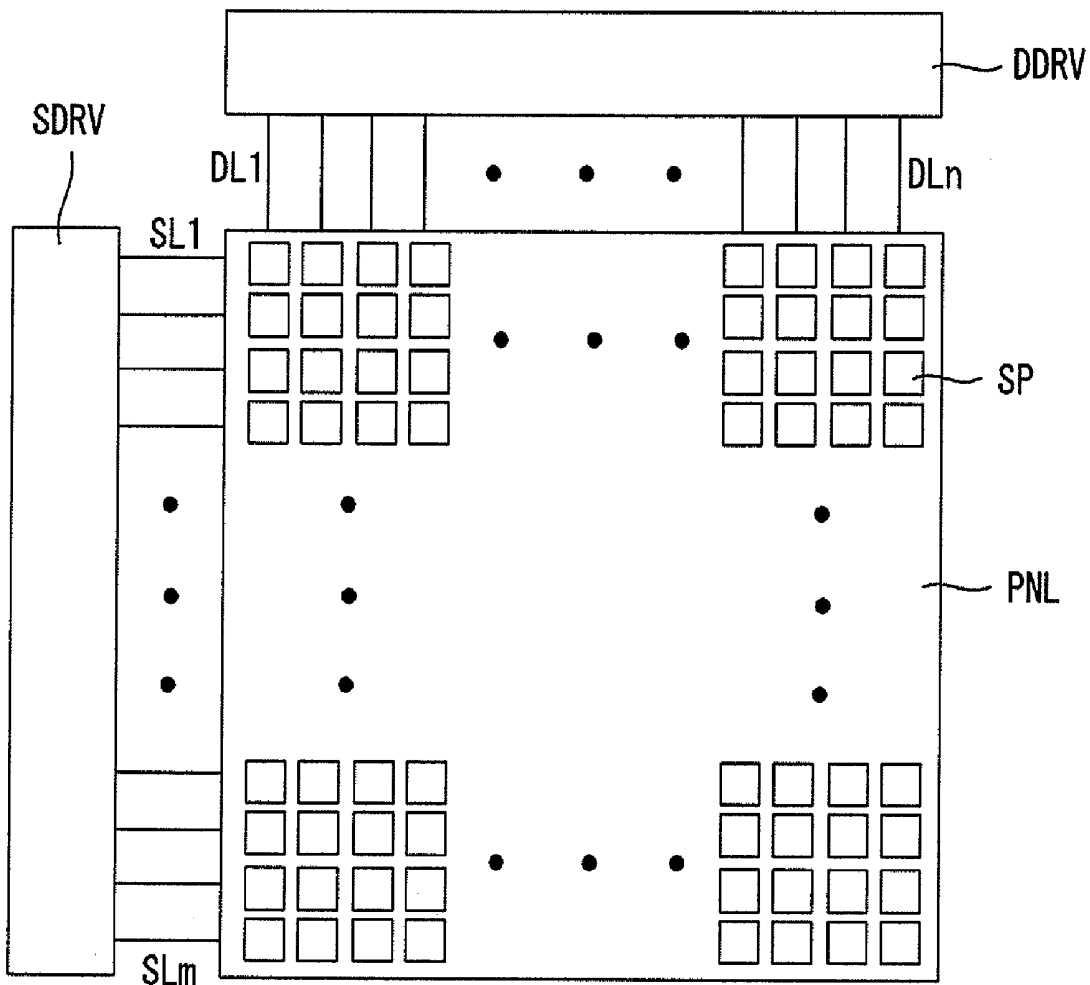

Fig. 1

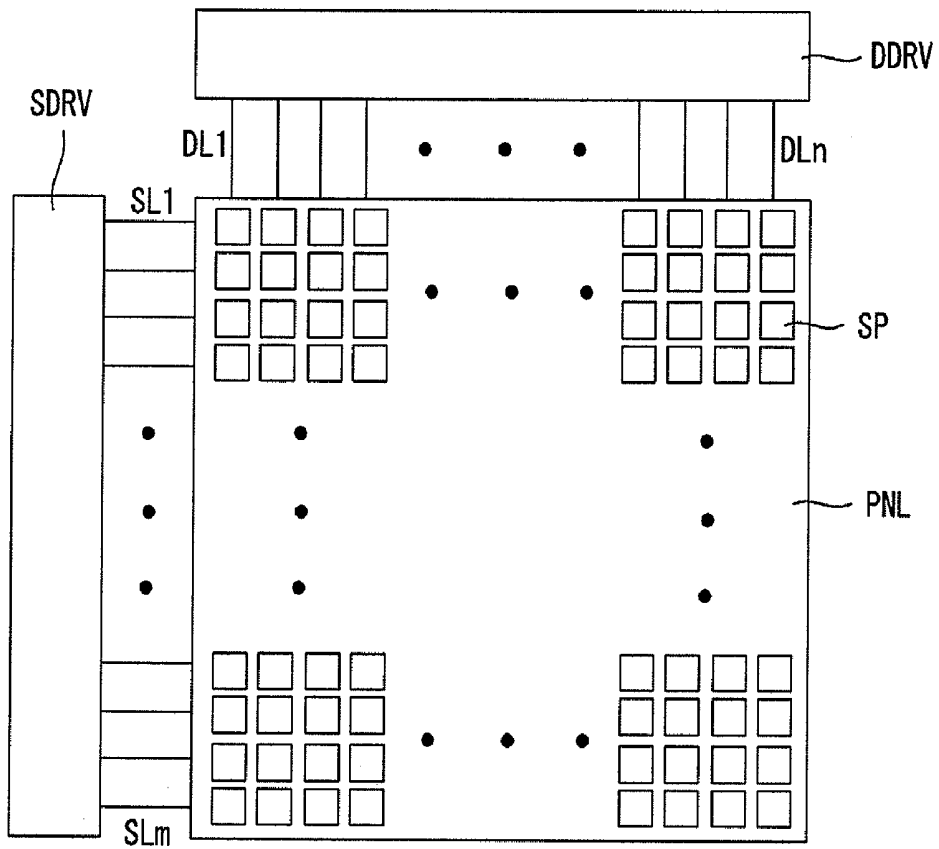

Fig. 2

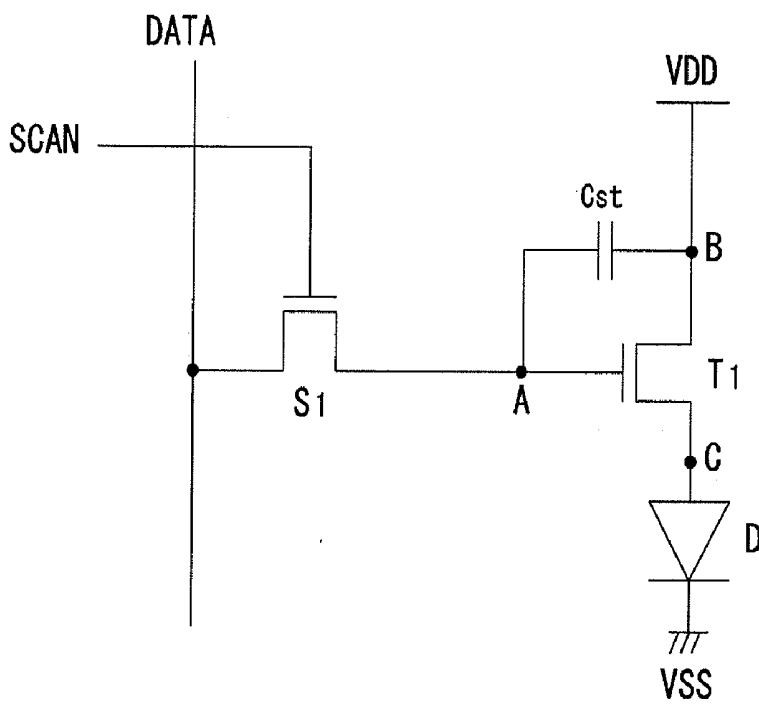

Fig. 3

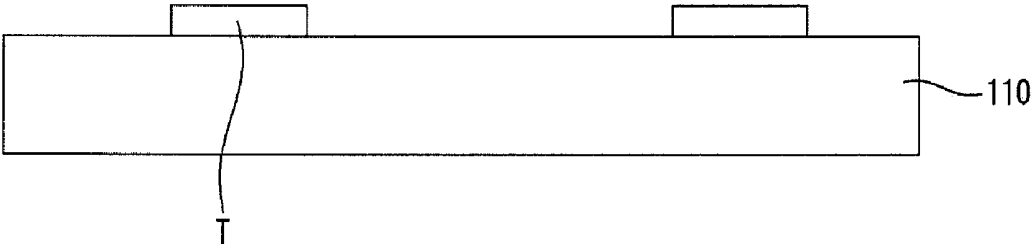

Fig. 4

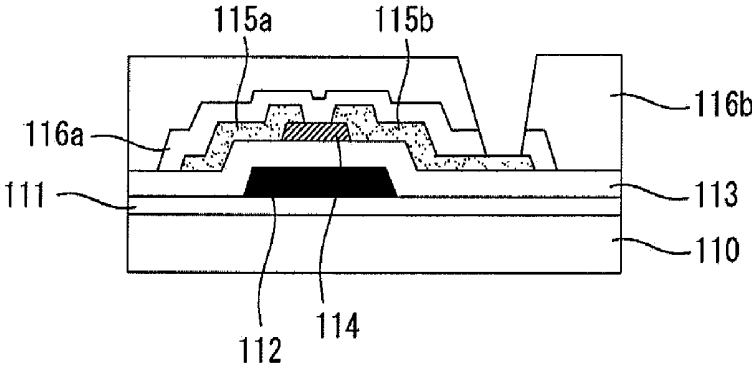

Fig. 5

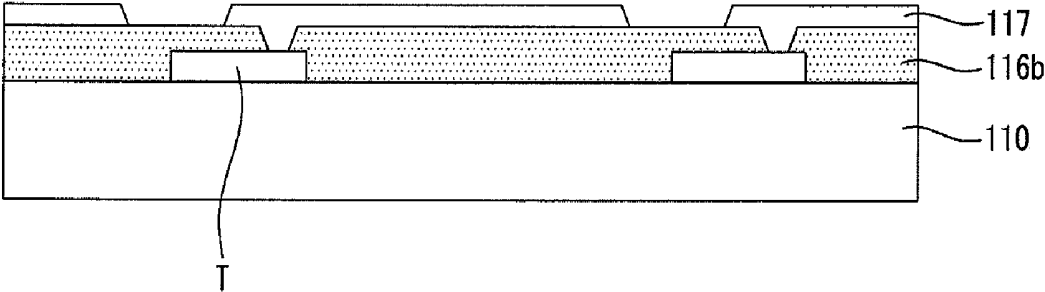

Fig. 6

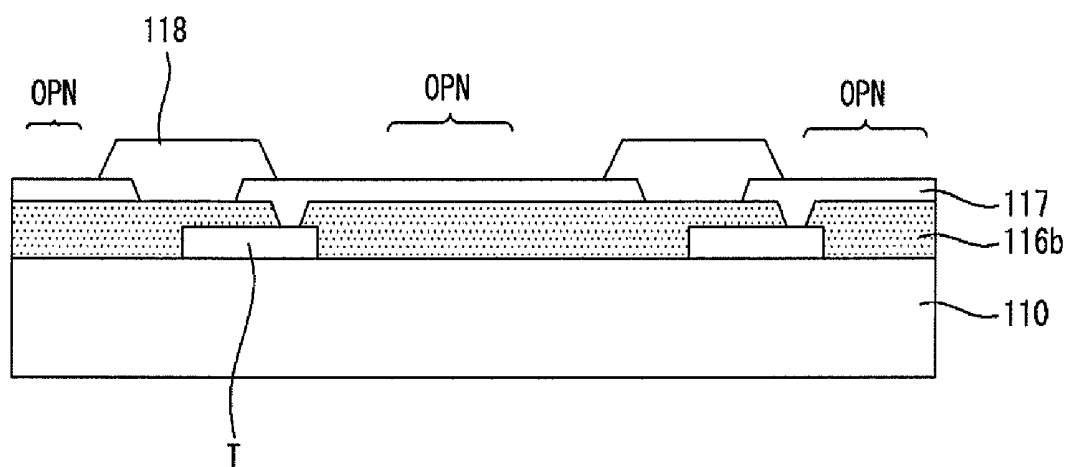

Fig. 7

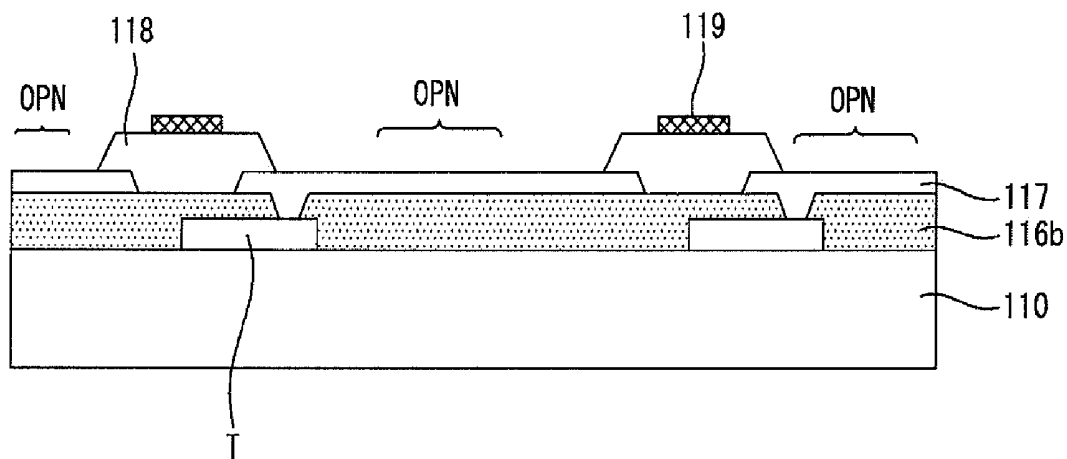

Fig. 8

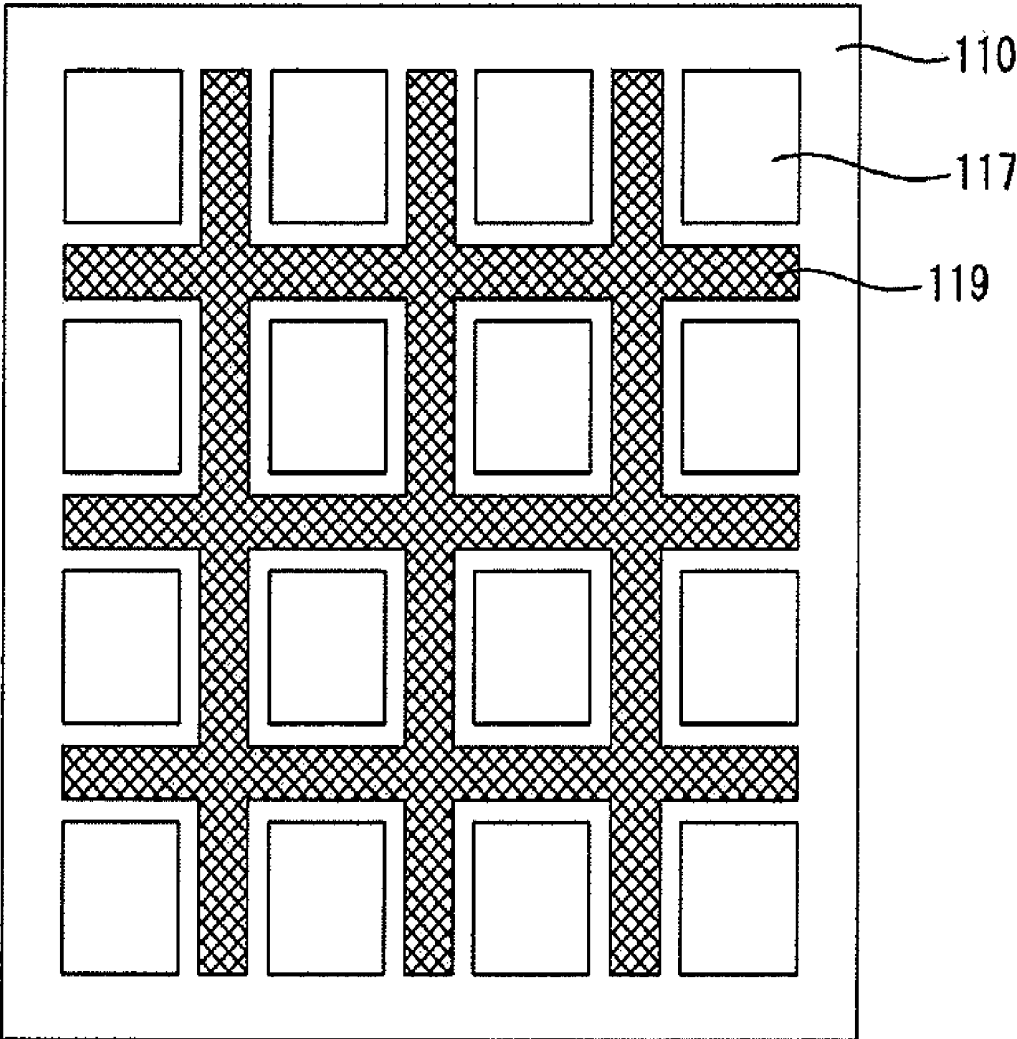

Fig. 9

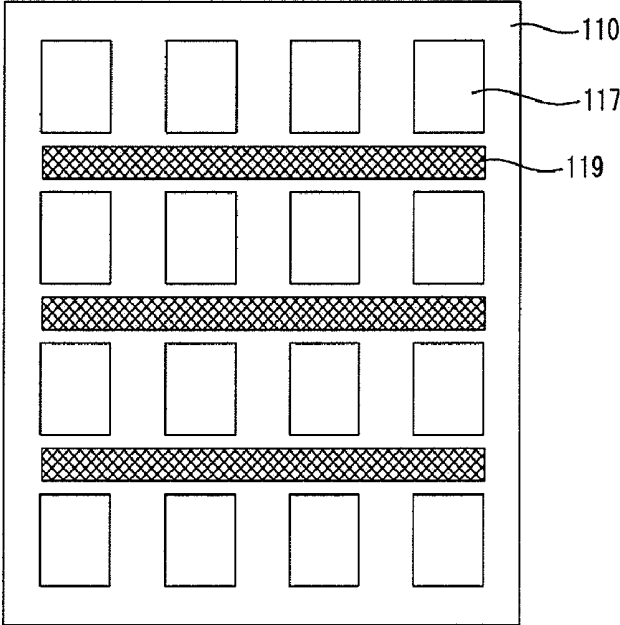

Fig. 10

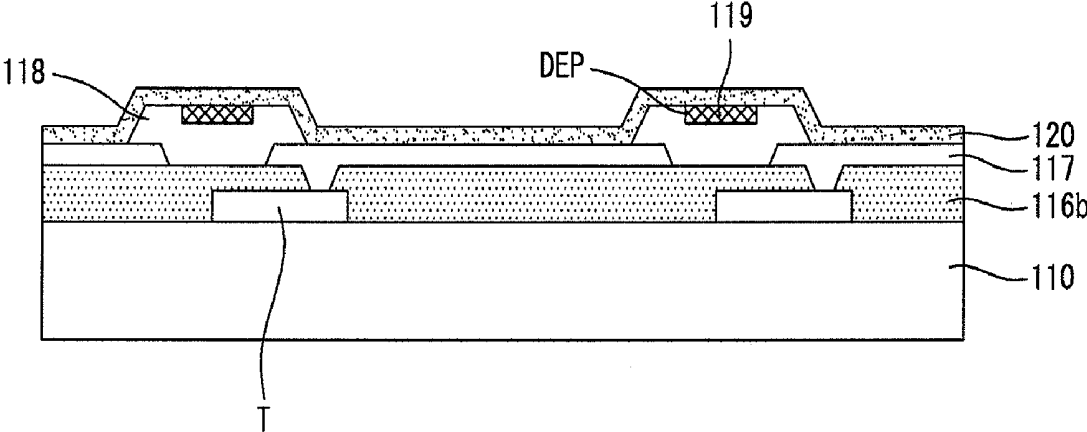

Fig. 11

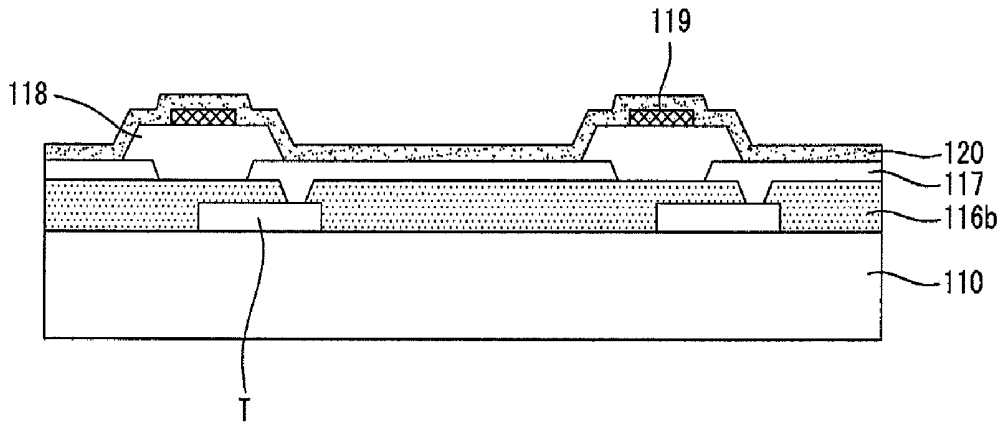

Fig. 12

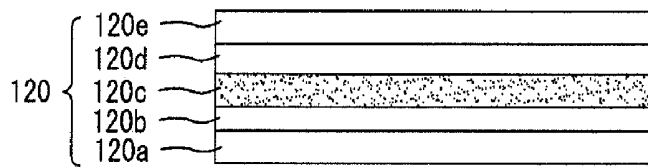

Fig. 13

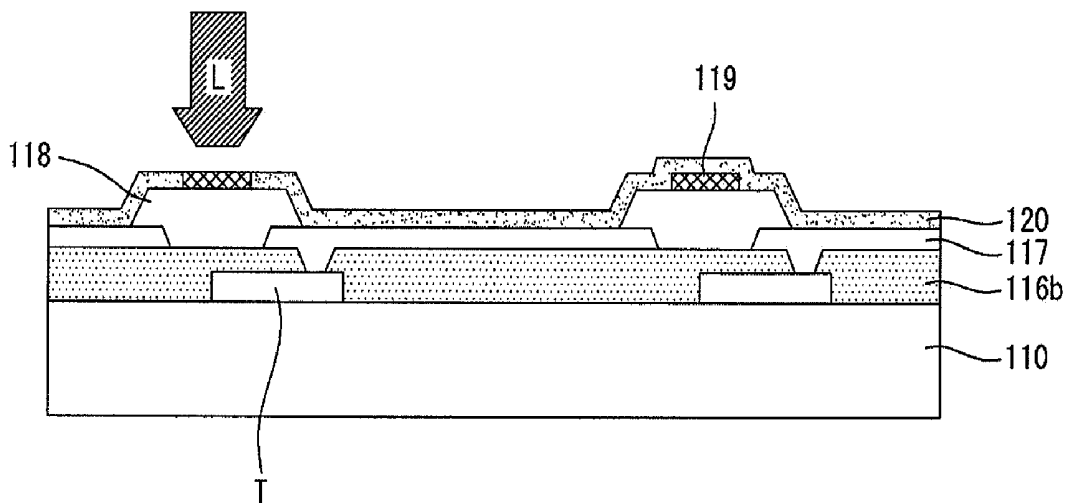

Fig. 14

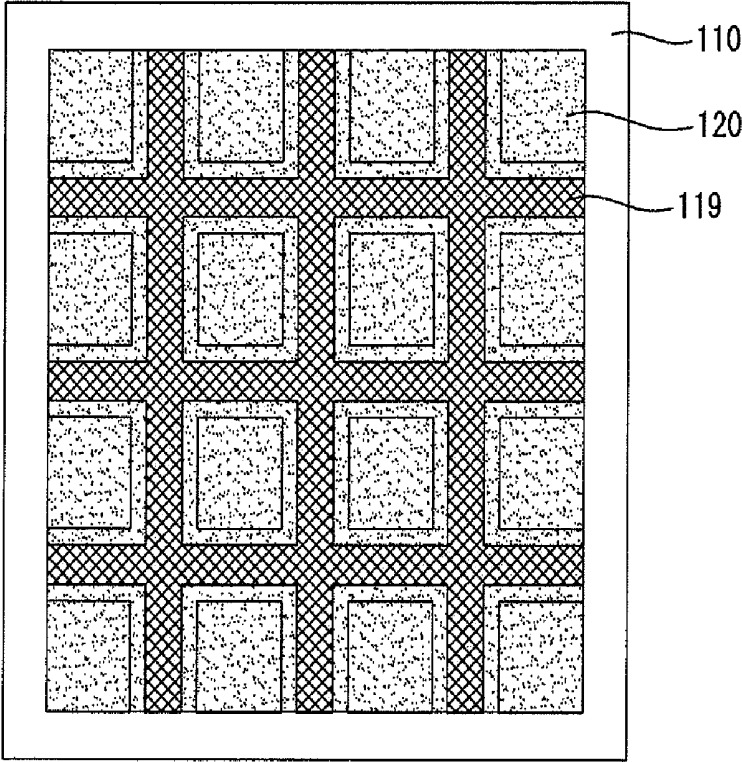

Fig. 15

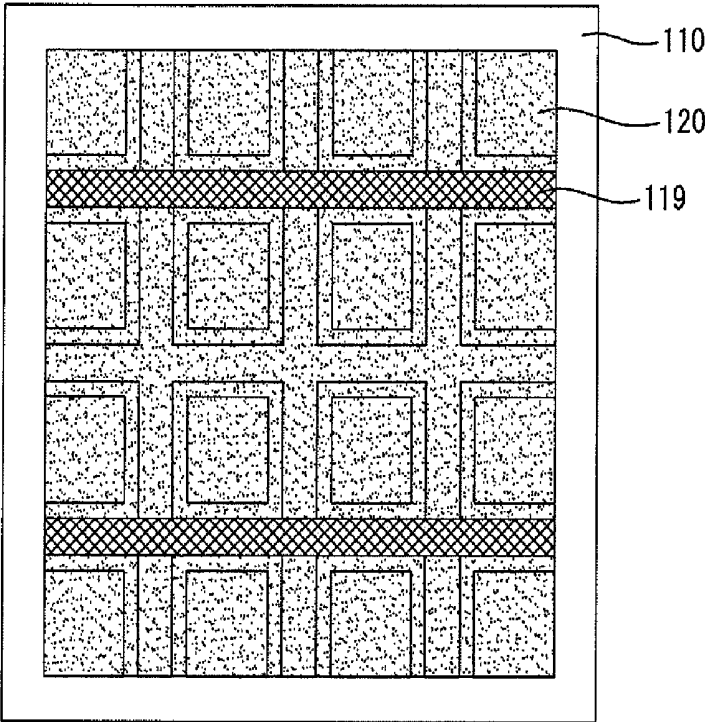

Fig. 16

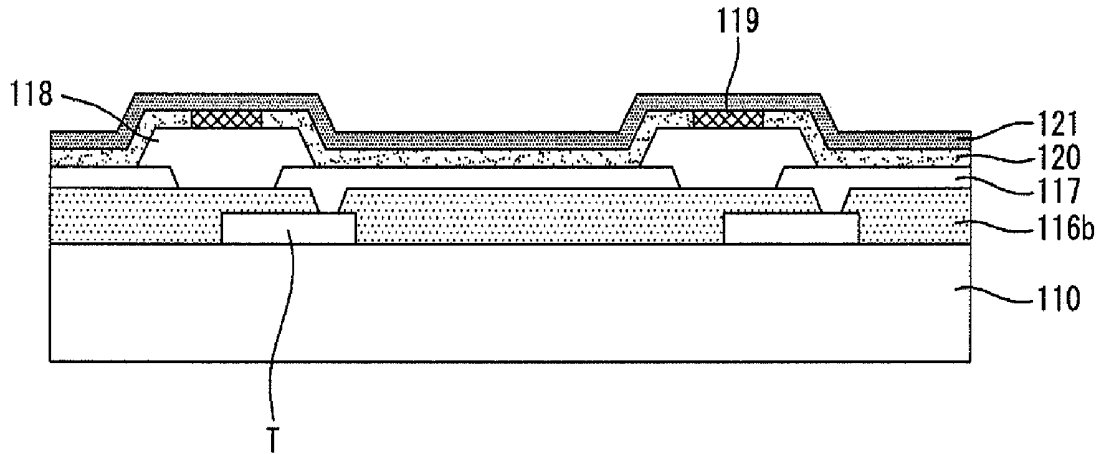

Fig. 17

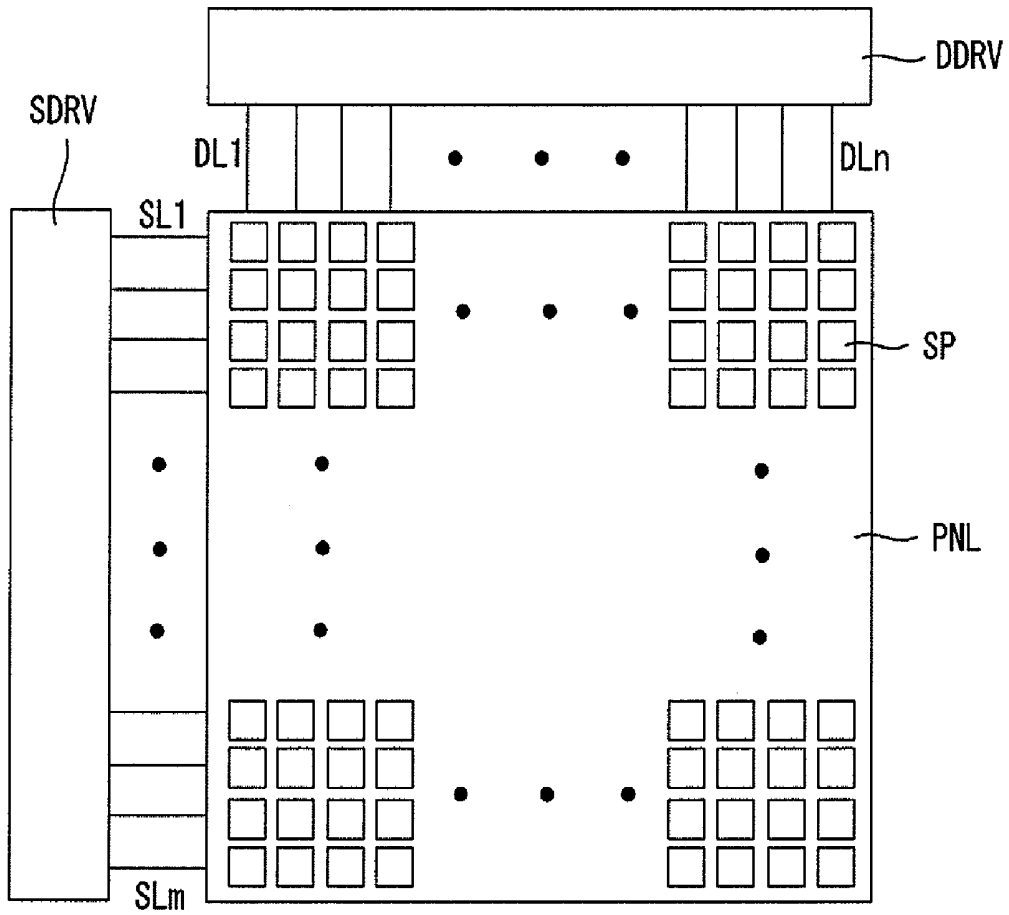

Fig. 18

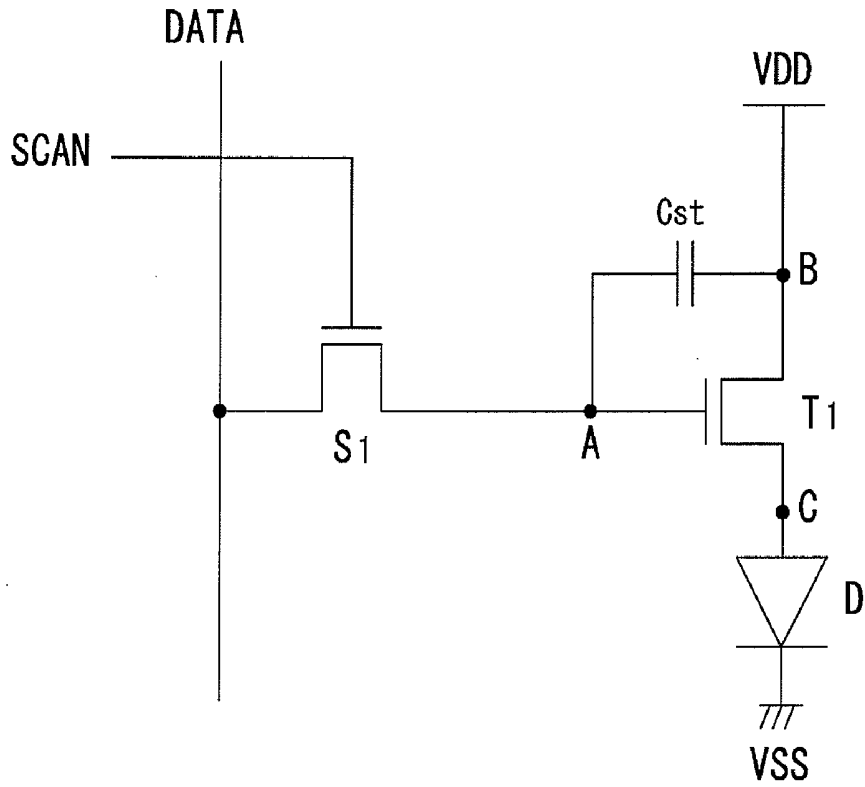

Fig. 19

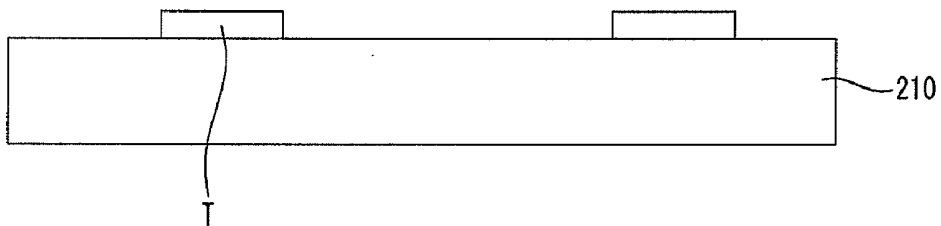

Fig. 20

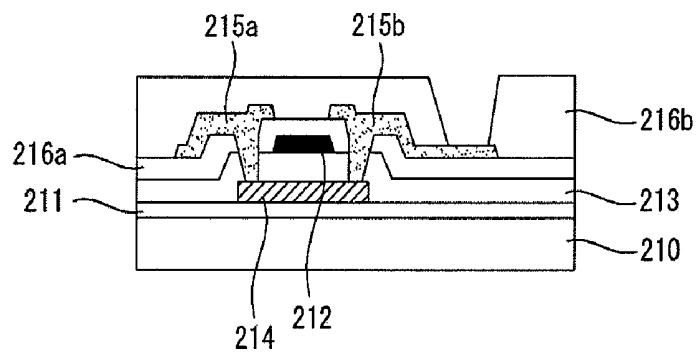

Fig. 21

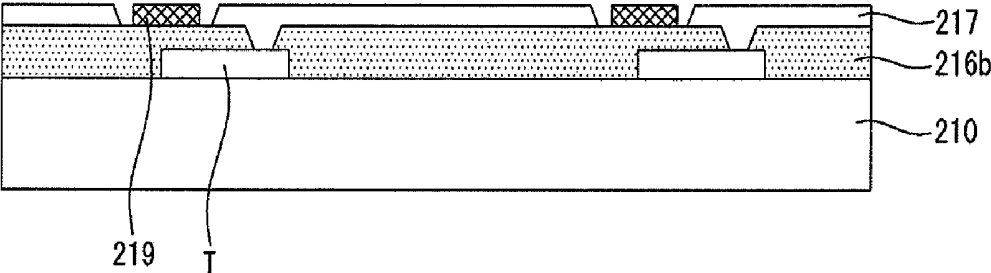

Fig. 22

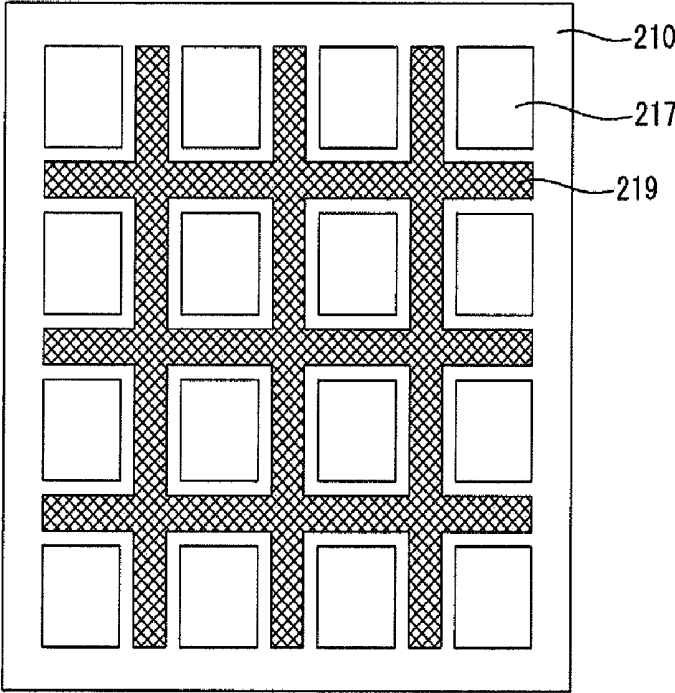

Fig. 23

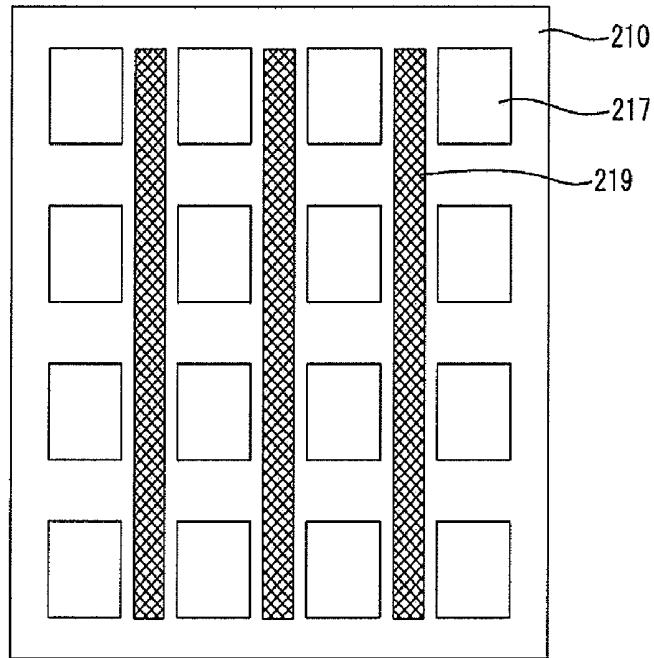

Fig. 24

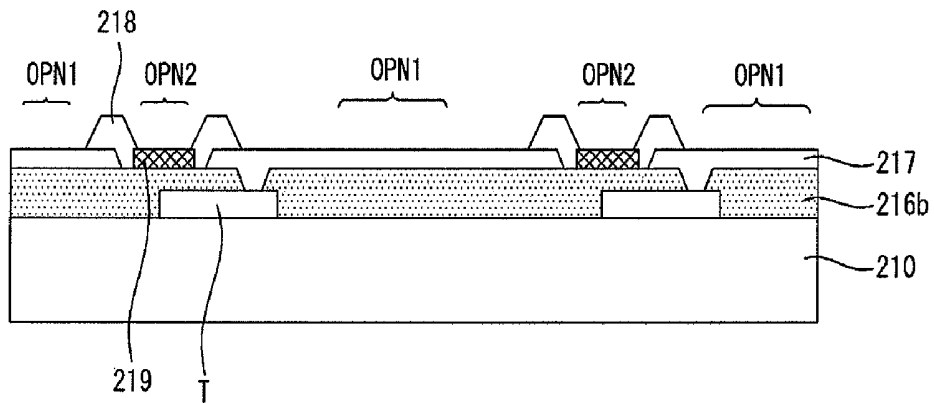

Fig. 25

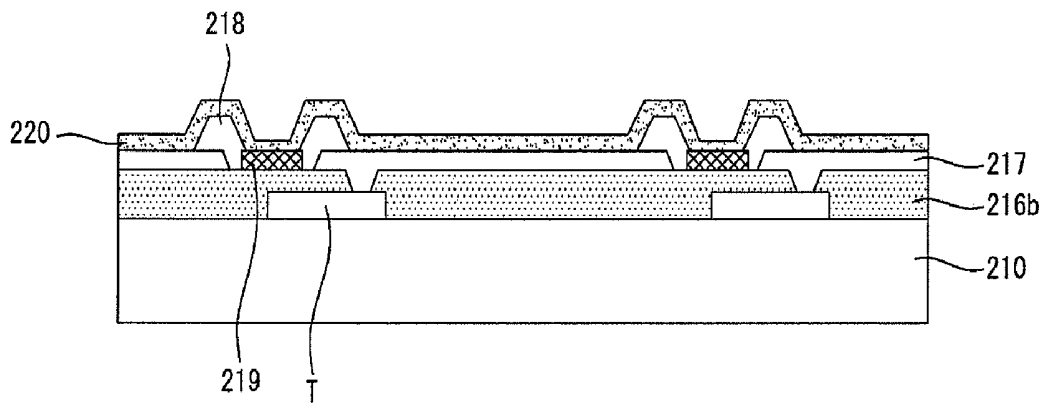

Fig. 26

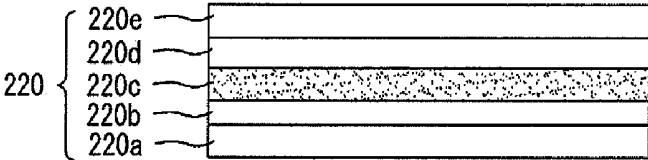

Fig. 27

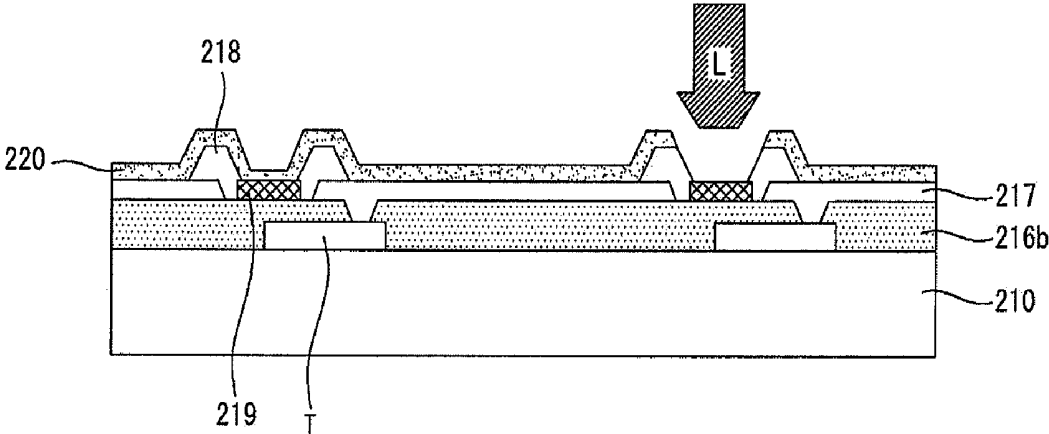

Fig. 28

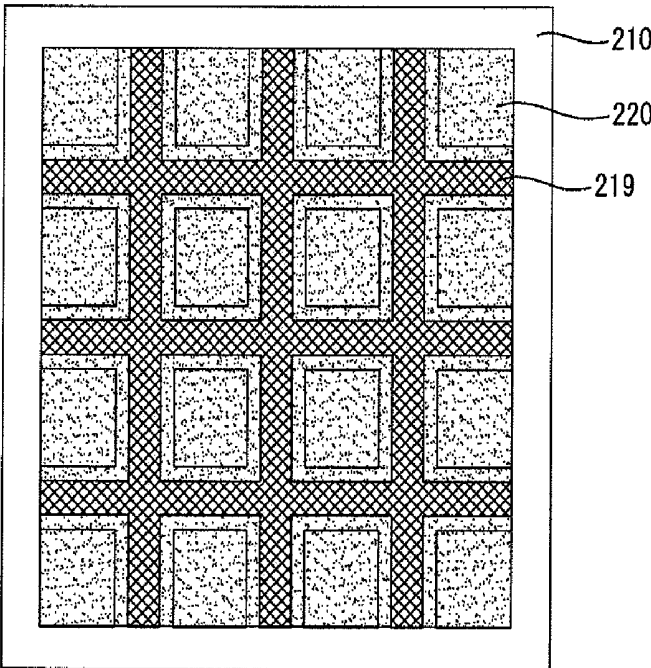

Fig. 29

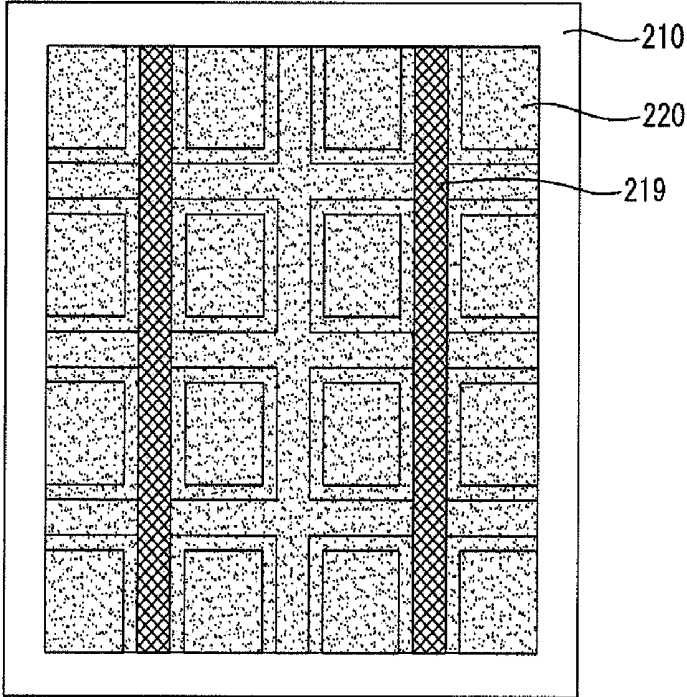
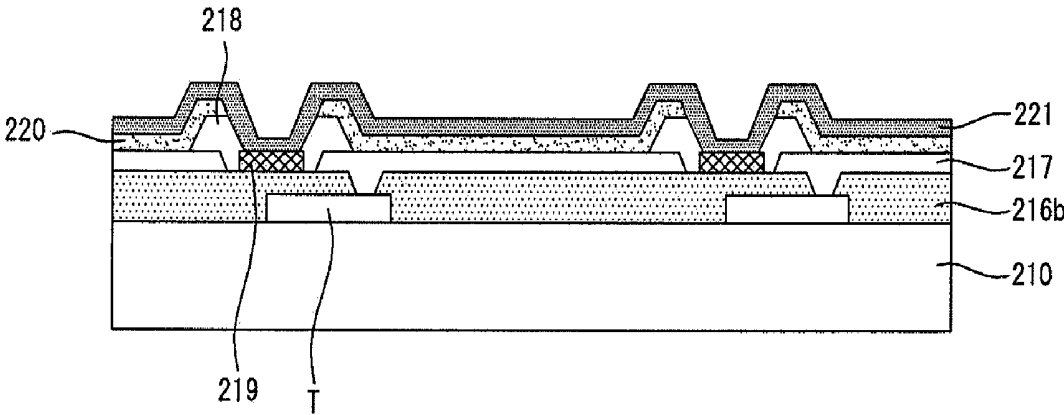

Fig. 30



## ORGANIC ELECTROLUMINESCENT DISPLAY DEVICE AND METHOD OF MANUFACTURING THE SAME

[0001] This application claims the benefit of Korean Patent Application No. 10-2009-0039313 filed on May 6, 2009, which is hereby incorporated by reference.

### BACKGROUND

[0002] 1. Field

[0003] This document relates to an organic electroluminescent display device and a method of manufacturing the same.

[0004] 2. Related Art

[0005] An organic electroluminescent device used in an organic electroluminescent display device is an emissive device in which an emission layer is formed between two electrodes disposed on a substrate. The organic electroluminescent display device operates according to a top-emission method, a bottom-emission method, or a dual-emission method according to the direction in which light is emitted. The organic electroluminescent display device is divided into a passive matrix type and an active matrix type according to its driving method.

[0006] Each of subpixels arranged in the organic electroluminescent display device comprises a transistor unit, a lower electrode, and an organic light-emitting diode. The transistor unit comprises a switching transistor, a driving transistor, and a capacitor. The lower electrode is coupled to the driving transistor included in the transistor unit. The organic light-emitting diode comprises an organic light-emitting layer and an upper electrode. In this organic electroluminescent display device, when a scan signal, a data signal, power, etc. are supplied to the plurality of subpixels arranged in a matrix, selected subpixels emit light, thereby being capable of displaying an image.

[0007] Meanwhile, in the conventional organic electroluminescent display device, the resistance of electrodes formed in a panel is relatively high. Accordingly, when the conventional organic electroluminescent display device is used to implement large-sized display devices, there are problems such as rise in driving voltage and irregularity in luminance.

### SUMMARY

[0008] An aspect of this document is to provide a method of manufacturing an organic electroluminescent display device, comprising forming transistors on a substrate, forming an insulating layer in the transistors, forming a lower electrode on the insulating layer, the lower electrode being coupled to a source or a drain of each of the transistors, forming a bank layer on the lower electrode, the bank layer having openings to expose part of the lower electrode, forming a bus electrode on the bank layer, forming an organic light-emitting layer to cover the lower electrode, the bank layer, and the bus electrode, patterning the organic light-emitting layer using a laser, thereby exposing at least part of the bus electrode placed on the bank layer, and forming an upper electrode on the organic light-emitting layer so that the upper electrode comes into contact with the exposed bus electrode.

[0009] Another aspect of this document is to provide a method of manufacturing an organic electroluminescent display device, comprising forming transistors on a substrate, forming an insulating layer on the transistors, forming a lower

electrode on an insulating layer, the lower electrode being coupled to a source or a drain of each of the transistors, forming a bus electrode on the insulating layer, the bus electrode being separated from the lower electrode and formed on the same layer as the lower electrode, forming a bank layer on the lower electrode and the bus electrode, the bank layer having openings to respectively expose the lower electrode and the bus electrode, forming an organic light-emitting layer to cover the lower electrode, the bus electrode, the bank layer, and the bus electrode, patterning the organic light-emitting layer using a laser, thereby exposing at least part of the bus electrode placed on the bank layer, and forming an upper electrode on the organic light-emitting layer so that the upper electrode comes into contact with the exposed bus electrode.

[0010] Yet another aspect of this document is to provide an organic electroluminescent display device, comprising transistors formed on a substrate, an insulating layer on the transistors, a lower electrode formed on the insulating layer and coupled to a source or a drain of each of the transistors, a bank layer having openings to expose part of the lower electrode, a bus electrode formed on the bank layer, an organic light-emitting layer formed to cover the lower electrode, the bank layer, and the bus electrode and patterned to expose at least part of the bus electrode, and an upper electrode formed on the organic light-emitting layer and configured to come into contact with the exposed bus electrode.

[0011] Still another aspect of this document is to provide an organic electroluminescent display device, comprising transistors formed on a substrate, an insulating layer on the transistors, a lower electrode formed on the insulating layer and coupled to a source or a drain of each of the transistors, a bus electrode formed on the same layer as the lower electrode and separated from the lower electrode, a bank layer having openings to respectively expose the lower electrode and the bus electrode, an organic light-emitting layer formed to cover the lower electrode, the bank layer, and the bus electrode and patterned to expose at least part of the bus electrode, and an upper electrode formed on the organic light-emitting layer and configured to come into contact with the exposed bus electrode.

### BRIEF DESCRIPTION OF THE DRAWINGS

[0012] The accompany drawings, which are included to provide a further understanding of this document and are incorporated in and constitute a part of this specification, illustrate embodiments of this document and together with the description serve to explain the principles of this document.

[0013] FIG. 1 is a schematic block diagram of an organic electroluminescent display device according to an embodiment of this document;

[0014] FIG. 2 is an exemplary view showing the circuit construction of a subpixel shown in FIG. 1;

[0015] FIGS. 3 through 16 are diagrams showing a method of manufacturing the organic electroluminescent display device according to a first embodiment of this document;

[0016] FIG. 17 is a schematic block diagram of an organic electroluminescent display device according to a second exemplary embodiment of this document;

[0017] FIG. 18 is an exemplary view showing the circuit construction of a subpixel shown in FIG. 17; and

[0018] FIGS. 19 through 30 are diagrams showing a method of manufacturing the organic electroluminescent display device according to a second embodiment of this document.

#### DETAILED DESCRIPTION

[0019] Detailed reference will now be made to embodiments of this document, examples of which are illustrated in the accompanying drawings.

##### First Embodiment

[0020] Referring to FIGS. 1 and 2, an organic electroluminescent display device according to a first embodiment of this document may comprise a panel PNL comprising subpixels SP arranged in a matrix, a scan driver SDRV configured to supply the scan lines SL1, . . . , SLm of the subpixels SP with scan signals, and a data driver DDRV configured to supply the data lines DL1, . . . , DLn of the subpixels SP with data signals.

[0021] Each of the subpixels SP may have a 2T1C (Transistor 1C/Capacitor) structure, comprising a switching transistor S1, a driving transistor T1, a capacitor Cst, and an organic light-emitting diode D, or a structure in which another transistor or capacitor is further added to the 2T1C structure.

[0022] In the 2T1C structure, the elements included in the subpixel SP may be coupled together as follows. The switching transistor S1 has a gate coupled to the scan line SL1 from which a scan signal SCAN is supplied, one terminal coupled to the data line DL1 from which a data signal DATA is supplied, and the other terminal coupled to a first node A. The driving transistor T1 has a gate coupled to the first node A, one terminal coupled to a second node B and a first power source line VDD from which a high electric potential is supplied, and the other terminal coupled to a third node C. The capacitor Cst has one terminal coupled to the first node A and the other terminal coupled to the second node B. The organic light-emitting diode D has an anode coupled to the third node C and a cathode coupled to a second power source line VSS from which a low electric potential is supplied.

[0023] Although an example in which the transistors S1 and T1 included in the subpixel SP have an N-type configuration has been described above, embodiments of this document are not limited to the above example. Further, the high electric potential supplied from the first power source line VDD may be higher than the low electric potential supplied from the second power source line VSS, and the levels of power sources supplied from the first power source line VDD and the second power source line VSS may be switched according to a driving method.

[0024] The above-described subpixel SP may operate as follows. When the scan signal SCAN is supplied through the scan line SL1, the switching transistor S1 is turned on. When the data signal DATA supplied through the data line DL1 is supplied to the first node A via the turned-on switching transistor S, the data signal is stored in the capacitor Cst in the form of a data voltage. When the supply of the scan signal is stopped and the switching transistor S1 is turned off, the driving transistor T1 is driven in response to the data voltage stored in the capacitor Cst. When the high electric potential supplied through the first power source line VDD flows through the second power source line VSS, the organic light-emitting diode D emits light. It is to be noted that the above driving method is only an example, and embodiments of this document are not limited to the example.

[0025] The organic electroluminescent display device of this document may be manufactured using the following method.

[0026] Referring to FIGS. 3 and 4, transistors T are formed on a substrate 110. The transistors T may be divided into a bottom gate-type transistor having a gate disposed on its bottom and a top gate-type transistor having a gate disposed on its top. In this embodiment, a structure of the bottom gate-type transistor is described as an example, for convenience.

[0027] The transistor T corresponds to the driving transistor included in the subpixel. The transistor T is formed on the substrate 110. The substrate 110 may be made of a material which has excellent mechanical strength or measurement stability. The substrate 110 may be made of, for example, a glass plate, a metal plate, a ceramic plate, or a plastic plate (polycarbonate resin, acrylic resin, vinyl chloride resin, polyethylene terephthalate resin, polyimide resin, polyester resin, epoxy resin, silicon resin, fluoride resin, etc.). A method of manufacturing the bottom gate-type transistor is described below.

[0028] A buffer layer 111 is formed on the substrate 110. The buffer layer 111 may be formed in order to protect a thin film transistor, formed in a subsequent process, from impurities, such as alkali ions drained from the substrate 110, and may be omitted. The buffer layer 111 may be made of silicon oxide (SiOx) or silicon nitride (SiNx).

[0029] A gate 112 is formed on the buffer layer 111. The gate 112 may be made of one selected from the group consisting of molybdenum (Mo), aluminum (Al), chrome (Cr), gold (Au), titanium (Ti), nickel (Ni), neodymium (Nd), and copper (Cu), or an alloy thereof. Further, the gate 112 may be either a single layer of one selected from the group consisting of molybdenum (Mo), aluminum (Al), chrome (Cr), gold (Au), titanium (Ti), nickel (Ni), neodymium (Nd), and copper (Cu), or a multilayer made of an alloy thereof. Alternatively, the gate 112 may be a dual layer made of Mo/Al—Nd or Mo/Al.

[0030] A first insulating layer 113 is formed on the gate 112. The first insulating layer 113 may be a single layer of silicon oxide (SiOx) or silicon nitride (SiNx), or a multilayer thereof, but is not limited thereto.

[0031] An active layer 114 is formed on the first insulating layer 113. The active layer 114 may comprise amorphous silicon or polycrystalline silicon which is crystallized amorphous silicon. Although not shown in the drawing, the active layer 114 may comprise a channel region, a source region, and a drain region. The source region and the drain region may be doped with a P-type or N-type impurity. Further, the active layer 114 may comprise an ohmic contact layer for lowering contact resistance.

[0032] A source 115a and a drain 115b are formed on the active layer 114. The source 115a and the drain 115b may be formed of a single layer or a multilayer. When the source 115a and the drain 115b are formed of a single layer, they may be made of any one selected from the group consisting of molybdenum (Mo), aluminum (Al), chrome (Cr), gold (Au), titanium (Ti), nickel (Ni), neodymium (Nd), and copper (Cu), or an alloy thereof. When the source 115a and the drain 115b are formed of a multilayer, they may be formed of a dual layer of Mo/Al—Nd or a triple layer of Mo/Al/Mo or Mo/Al—Nd/Mo.

[0033] A second insulating layer 116a is formed on the source 115a and the drain 115b. The second insulating layer

**116a** may be formed of a single layer of silicon oxide (SiOx) or silicon nitride (SiNx), or a multilayer thereof, but is not limited thereto. The second insulating layer **116a** may be a passivation layer. A third insulating layer **116b** is formed on the second insulating layer **116a**. The third insulating layer **116b** may be formed of a single layer of silicon oxide (SiOx) or silicon nitride (SiNx), or a multilayer thereof, but is not limited thereto. The third insulating layer **116b** may be a polishing layer for increasing the degree of flatness of a surface. The above-described transistor has been illustrated to aid in understanding the exemplary embodiment, but may have a different structure according to a mask process.

[0034] Referring to FIG. 5, a lower electrode **117** is coupled to the source **115a** or the drain **115b** of the transistor T. In other words, the lower electrode **117** is formed on the third insulating layer **116b** so that it is coupled to the source **115a** or the drain **115b** of the transistor T. In this embodiment, the lower electrode **117** may be selected as an anode. The lower electrode **117** selected as an anode may be made of a transparent conductive material, such as indium tin oxide (ITO), indium zinc oxide (IZO), indium tin zinc oxide (ITZO), or Al<sub>2</sub>O<sub>3</sub> doped ZnO (AZO), but is not limited thereto.

[0035] Referring to FIG. 6, a bank layer **118** is formed to have openings OPN through which part of the lower electrode **117** is exposed. The bank layer **118** may be made of an organic material, such as benzocyclobutene (BCB) resin, acrylic resin, or polyimide resin, but is not limited thereto. Since the openings OPN through which part of the lower electrode **117** is exposed are formed when the bank layer **118** is formed, the light-emitting region of the subpixel may be defined.

[0036] Referring to FIG. 7, a bus electrode **119** is formed on the bank layer **118**. The bus electrode **119** may be made of the same material as the lower electrode **117** or different material. The bus electrode **119** may have a single layer structure or a multilayer structure made of at least one selected from among molybdenum (Mo), aluminum (Al), chrome (Cr), gold (Au), titanium (Ti), nickel (Ni), neodymium (Nd), and copper (Cu). Meanwhile, as shown in FIGS. 8 and 9, the bus electrode **119** may be formed in a mesh (refer to FIG. 8) or stripes (refer to FIG. 9), but is not limited thereto. Referring to FIG. 10, when the bus electrode **119** is formed on the bank layer **118**, patterning for the bank layer **118** may be performed so that part of the bank layer **118** is depressed and the bus electrode **119** may be formed in the depressed portion DEP. In this case, since the bus electrode **119** may become thick, an electrode with low resistance can be implemented.

[0037] Referring to FIG. 11, an organic light-emitting layer **120** is formed to cover the lower electrode **117**, the bank layer **118**, and the bus electrode **119**. The organic light-emitting layer **120** is formed in such a way as to cover the lower electrode **117**, the bank layer **118**, and the bus electrode **119** formed on the substrate **110**. Referring to FIG. 12, the organic light-emitting layer **120** may comprise a hole injection layer **120a**, a hole transport layer **120b**, an emission layer **120c**, an electron transport layer **120d**, and an electron injection layer **120e**. The hole injection layer **120a** may function to smooth the injection of holes. The hole injection layer **120a** may be made of one or more selected from the group consisting of CuPc (copper phthalocyanine), PEDOT (poly(3,4)-ethylenedioxythiophene), PANI (polyaniline), and NPD(N,N-dinaphthyl-N,N'-diphenyl benzidine), but is not limited thereto. The hole transport layer **120b** may function to smooth the injection of electrons. The hole transport layer **120b** may be made

of one or more selected from the group consisting of NPD(N,N-dinaphthyl-N,N'-diphenyl benzidine), TPD(N,N'-bis-(3-methylphenyl)-N,N'-bis-(phenyl)-benzidine), and s-TAD, MTDATA(4,4',4''-Tris(N-3-methylphenyl-N-phenyl-amino)-triphenylamine), but is not limited thereto. The emission layer **120c** may comprise a material that emits red, green, blue, or white light and may be made of a phosphorescent or fluorescent material. In the case where the emission layer **120c** is made of a material that emits red light, the emission layer **120c** may be made of a phosphorescent material comprising a host materials comprising carbazole biphenyl (CBP) or 1,3-bis(carbazol-9-y1) (mCP), and a dopant comprising one or more selected from the group consisting of PIQIr(acac)(bis(1-phenylisoquinoline)acetylacetonate iridium), PQIr(acac)(bis(1-phenylquinoline)acetylacetonate iridium), PQIr(tris(1-phenylquinoline)iridium), and PtOEP(octaethylporphyrin platinum). Alternatively, the emission layer **120c** may be made of a fluorescent material comprising PBD:Eu (DBM)3(Phen) or Perylene, but is not limited thereto. In the case where the emission layer **120c** is made of a material that emits green light, the emission layer **120c** may be made of a phosphorescent material comprising a host material comprising CBP or mCP, and a dopant material comprising Ir(ppy)3 (fac tris(2-phenylpyridine)iridium). Alternatively, the emission layer **120c** may be made of a fluorescent material comprising Alq3(tris(8-hydroxyquinolino)aluminum), but is not limited thereto. In the case where the emission layer **120c** is made of a material that emits blue light, the emission layer **120c** may be made of a phosphorescent material comprising a host material comprising CBP or mCP and a dopant material comprising (4,6-F2 ppy)2Irpic. Alternatively, the emission layer **120c** may be made of a fluorescent material comprising any one selected from the group consisting of spiro-DPVBi, spiro-6P, distyrylbenzene (DSB), distyrylarylene (DSA), PFO polymer, and PPV polymer, but is not limited thereto. The electron transport layer **120d** may function to smooth the transport of electrons. The electron transport layer **120d** may be made of one or more selected from the group consisting of Alq3(tris(8-hydroxyquinolino)aluminum), PBD, TAZ, spiro-PBD, BALq, and SALq, but is not limited thereto. The electron injection layer **120e** may function to smooth the injection of electrons. The electron injection layer **120e** may be made of Alq3(tris(8-hydroxyquinolino)aluminum), PBD, TAZ, spiro-PBD, BALq, or SALq, but is not limited thereto. Note that this document is not limited to the above examples, and at least one of the hole injection layer **120a**, the hole transport layer **120b**, the electron transport layer **120d**, and the electron injection layer **120e** may be omitted.

[0038] Referring to FIG. 13, the organic light-emitting layer **120** is patterned so that the bus electrode **119** formed on the bank layer **118** is exposed. The organic light-emitting layer **120** is patterned using a laser L. If the organic light-emitting layer **120** is patterned using the laser L as described above, light energy emitted from the laser L is transformed into thermal energy, so a boundary portion of the organic light-emitting layer **120** and the bus electrode **119** is sublimated. Meanwhile, when the organic light-emitting layer **120** is patterned using the laser L, a region where the bus electrode **119** is formed may be fully patterned as shown in FIG. 14, or locally patterned as shown in FIG. 15.

[0039] Referring to FIG. 16, an upper electrode **121** is formed on the organic light-emitting layer **120** so that the upper electrode **121** comes into contact with the exposed bus electrode **119**. The upper electrode **121** may be selected as a

cathode. The upper electrode **121** selected as the cathode may have a single layer or multilayer structure made of a single material, such as Al, AlNd, or Ag, or a single layer or multilayer structure made of a complex material, such as Mg:Ag or Al/Ag. Alternatively, the upper electrode **121** may have a single layer or multilayer structure made of metal oxide, such as ITO, IZO, or ITZO, or an organic conductive material, but is not limited thereto. Here, the upper electrode **121** may be made of the above-described materials, but is formed thinly in order to enhance transparency. Accordingly, the light emitted from the organic light-emitting layer **120** can travel in the direction of the upper electrode **121**.

**[0040]** If the top emission-type organic electroluminescent display device is manufactured using the above method, the upper electrode **121** selected as a cathode in order to enhance transparency can be formed thinly. In particular, the resistance of the upper electrode **121** can be lowered because the bus electrode **119** and the upper electrode **121** formed on the bank layer **118** can be electrically coupled to each other without increasing a mask process. The organic electroluminescent display device having the above structure can lower a driving voltage and so solve the problem of luminance irregularity. Accordingly, problems (e.g., a rise in the driving voltage and luminance irregularity) occurring when a large-sized display device is implemented using an organic electroluminescent display device can be improved.

#### Second Embodiment

**[0041]** Referring to FIGS. **17** and **18**, an organic electroluminescent display device according to a second embodiment of this document may comprise a panel PNL comprising subpixels SP arranged in a matrix, a scan driver SDRV configured to supply the scan lines SL<sub>1</sub>, . . . , SL<sub>m</sub> of the subpixels SP with scan signals, and a data driver DDRV configured to supply the data lines DL<sub>1</sub>, . . . , DL<sub>n</sub> of the subpixels SP with data signals.

**[0042]** Each of the subpixels SP may have a 2T1C structure, comprising a switching transistor S<sub>1</sub>, a driving transistor T<sub>1</sub>, a capacitor C<sub>st</sub>, and an organic light-emitting diode D, or a structure in which another transistor or capacitor is further added to the 2T1C structure.

**[0043]** In the 2T1C structure, the elements included in the subpixel SP may be coupled together as follows. The switching transistor S<sub>1</sub> has a gate coupled to the scan line SL<sub>1</sub> from which a scan signal SCAN is supplied, one terminal coupled to the data line DL<sub>1</sub> from which a data signal DATA is supplied, and the other terminal coupled to a first node A. The driving transistor T<sub>1</sub> has a gate coupled to the first node A, one terminal coupled to a second node B and a first power source line VDD from which a high electric potential is supplied, and the other terminal coupled to a third node C. The capacitor C<sub>st</sub> has one terminal coupled to the first node A and the other terminal coupled to the second node B. The organic light-emitting diode D has an anode coupled to the third node C and a cathode coupled to a second power source line VSS from which a low electric potential is supplied.

**[0044]** Although an example in which the transistors S<sub>1</sub> and T<sub>1</sub> included in the subpixel SP have an N-type configuration has been described above, embodiments of this document are not limited to the above example. Further, the high electric potential supplied from the first power source line VDD may be higher than the low electric potential supplied from the second power source line VSS, and the levels of power sources supplied from the first power source line VDD

and the second power source line VSS may be switched according to a driving method.

**[0045]** The above-described subpixel SP may operate as follows. When the scan signal SCAN is supplied through the scan line SL<sub>1</sub>, the switching transistor S<sub>1</sub> is turned on. When the data signal DATA supplied through the data line DL<sub>1</sub> is supplied to the first node A via the turned-on switching transistor S, the data signal is stored in the capacitor C<sub>st</sub> in the form of a data voltage. When the supply of the scan signal is stopped and the switching transistor S<sub>1</sub> is turned off, the driving transistor T<sub>1</sub> is driven in response to the data voltage stored in the capacitor C<sub>st</sub>. When the high electric potential supplied through the first power source line VDD flows through the second power source line VSS, the organic light-emitting diode D emits light. Note that the above driving method is only an example, and embodiments of this document are not limited to the example.

**[0046]** The organic electroluminescent display device comprising the above-described subpixel may be manufactured using the following method.

**[0047]** Referring to FIGS. **19** and **20**, transistors T are formed on a substrate **210**. The transistors T may be divided into bottom gate-type transistors having a gate disposed on their bottom and top gate-type transistors having a gate disposed on their top. In this embodiment, a structure of the top gate-type transistors is described as an example, for convenience.

**[0048]** The transistor T corresponds to the driving transistor included in the subpixel. The transistor T is formed on the substrate **210**. The substrate **210** may be made of a material which has excellent mechanical strength or measurement stability. The substrate **210** may be made of, for example, a glass plate, a metal plate, a ceramic plate, or a plastic plate (polycarbonate resin, acrylic resin, vinyl chloride resin, polyethylene terephthalate resin, polyimide resin, polyester resin, epoxy resin, silicon resin, fluoride resin, etc.). A method of manufacturing the bottom gate-type transistor is described below.

**[0049]** A buffer layer **211** is formed on the substrate **210**. The buffer layer **211** may be formed in order to protect a transistor, formed in a subsequent process, from impurities, such as alkali ions drained from the substrate **210**, and may be omitted. The buffer layer **211** may be made of silicon oxide (SiO<sub>x</sub>) or silicon nitride (SiN<sub>x</sub>).

**[0050]** An active layer **214** is formed on the buffer layer **211**. The active layer **214** may comprise amorphous silicon or polycrystalline silicon, which is crystallized amorphous silicon. Although not shown in the drawing, the active layer **214** may comprise a channel region, a source region, and a drain region. The source region and the drain region may be doped with P- or N-type impurities. Further, the active layer **214** may comprise an ohmic contact layer for lowering contact resistance.

**[0051]** A first insulating layer **213** is formed on the active layer **214**. The first insulating layer **213** may be a single layer of silicon oxide (SiO<sub>x</sub>) or silicon nitride (SiN<sub>x</sub>), or a multilayer thereof, but is not limited thereto.

**[0052]** A gate **212** is formed on the first insulating layer **213**. The gate **212** may be made of one selected from the group consisting of molybdenum (Mo), aluminum (Al), chrome (Cr), gold (Au), titanium (Ti), nickel (Ni), neodymium (Nd), and copper (Cu), or an alloy thereof. Further, the gate **212** may be either a single layer of one selected from the group consisting of molybdenum (Mo), aluminum (Al),

chrome (Cr), gold (Au), titanium (Ti), nickel (Ni), neodymium (Nd), and copper (Cu), or a multilayer made of an alloy thereof. Alternatively, the gate **212** may be a dual layer made of Mo/Al—Nd or Mo/Al.

**[0053]** A second insulating layer **216a** is formed on the first insulating layer **213** in such a way as to cover the gate **212**. The second insulating layer **216a** may be a single layer of silicon oxide (SiOx) or silicon nitride (SiNx), or a multilayer thereof, but is not limited thereto. The second insulating layer **216a** may be a passivation layer.

**[0054]** A source **215a** and a drain **215b**, respectively coming into contact with the source and drain regions of the active layer **214**, are formed on the second insulating layer **216a**. The source **215a** and the drain **215b** may be formed of a single layer or a multilayer. When the source **215a** and the drain **215b** are formed of a single layer, they may be made of any one selected from the group consisting of molybdenum (Mo), aluminum (Al), chrome (Cr), gold (Au), titanium (Ti), nickel (Ni), neodymium (Nd), and copper (Cu), or an alloy thereof. When the source **215a** and the drain **215b** are formed of a multilayer, they may be formed of a dual layer of Mo/Al—Nd or a triple layer of Mo/Al/Mo or Mo/Al—Nd/Mo.

**[0055]** A third insulating layer **216b** is formed on the source **215a** and the drain **215b**. The third insulating layer **216b** may be a single layer of silicon oxide (SiOx) or silicon nitride (SiNx), or a multilayer thereof, but is not limited thereto. The third insulating layer **216b** may be a polishing layer for increasing the degree of flatness of a surface. The above-described transistor has been illustrated to aid in understanding the embodiment, but may have a different structure according to a mask process.

**[0056]** Referring to FIG. 21, a lower electrode **217** is coupled to the source **215a** or the drain **215b** of the transistor T. In other words, the lower electrode **217** is formed on the third insulating layer **216b** so that it is coupled to the source **215a** or the drain **215b** of the transistor T. In this embodiment, the lower electrode **217** may be selected as a cathode. The lower electrode **217** selected as a cathode may be made of Al, AlNd, or Ag and formed thickly in order to increase reflectance.

**[0057]** Referring to FIG. 21, a bus electrode **219** separated from the lower electrode **217** is formed on the same layer as the lower electrode **217**. The bus electrode **219** may have a single layer structure or a multilayer structure made of at least one of molybdenum (Mo), aluminum (Al), chrome (Cr), gold (Au), titanium (Ti), nickel (Ni), neodymium (Nd), and copper (Cu). Meanwhile, the bus electrode **219** may be formed in a mesh (refer to FIG. 22) or stripes (refer to FIG. 23), but is not limited thereto.

**[0058]** Referring to FIG. 24, a bank layer **218** is formed. The bank layer **218** comprises openings OPN1 and OPN2 through which the lower electrode **217** and the bus electrode **219** are respectively exposed. The bank layer **218** may comprise an organic material, such as benzocyclobutene (BCB) resin, acrylic resin, or polyimide resin, but is not limited thereto. Since the openings OPN1 through which part of the lower electrode **217** is exposed are formed when the bank layer **218** is formed, the light-emitting region of the subpixel can be defined and, at the same time, the openings OPN2 through which the bus electrode **219** is exposed can be formed.

**[0059]** Referring to FIG. 25, an organic light-emitting layer **220** is formed to cover the lower electrode **217**, the bank layer **218**, and the bus electrode **219**. The organic light-emitting

layer **220** is formed so that it covers the lower electrode **217**, the bank layer **218**, and the bus electrode **219** formed on the substrate **210**. Referring to FIG. 26, the organic light-emitting layer **220** may comprise an electron injection layer **220a**, an electron transport layer **220b**, an emission layer **220c**, a hole transport layer **220d**, and a hole injection layer **220e**.

**[0060]** Referring to FIG. 27, the organic light-emitting layer **220** is patterned so that the bus electrode **219** placed on the bank layer **218** is exposed. The organic light-emitting layer **220** is patterned using a laser L. If the organic light-emitting layer **220** is patterned using the laser L as described above, light energy emitted from the laser L is transformed into thermal energy, so a boundary portion of the organic light-emitting layer **220** and the bus electrode **219** is sublimated. Meanwhile, when the organic light-emitting layer **220** is patterned using the laser L, a region where the bus electrode **219** is formed may be fully patterned (refer to FIG. 28) or locally patterned (refer to FIG. 29).

**[0061]** Referring to FIG. 30, an upper electrode **221** is formed on the organic light-emitting layer **220** so that the upper electrode **221** comes into contact with the exposed bus electrode **219**. The upper electrode **221** may be selected as an anode. The upper electrode **221** selected as the anode may be made of any one of ITO, IZO, ITZO, and AZO (Al<sub>2</sub>O<sub>3</sub> doped ZnO), but is not limited thereto.

**[0062]** If the top emission-type organic electroluminescent display device is manufactured using the above method, the upper electrode **221** selected as a cathode in order to increase transparency can be formed thinly. Accordingly, a problem of the organic light-emitting layer **220** being damaged by sputtering, etc. can be prevented. In particular, the resistance of the upper electrode **221** can be lowered because the bus electrode **219** and the upper electrode **221** formed on the bank layer **218** can be electrically coupled to each other without increasing a mask process. The organic electroluminescent display device having the above structure can lower a driving voltage and so solve the problem of luminance irregularity. Accordingly, problems (e.g., rise in driving voltage and luminance irregularity) occurring when a large-sized display device is implemented using an organic electroluminescent display device can be avoided.

**[0063]** The foregoing embodiments and advantages are merely exemplary and are not to be construed as limiting the present invention. The present teaching can be readily applied to other types of apparatuses. The description of the foregoing embodiments is intended to be illustrative, and not to limit the scope of the claims. Many alternatives, modifications, and variations will be apparent to those skilled in the art. In the claims, means-plus-function clauses are intended to cover the structures described herein as performing the recited function and not only structural equivalents but also equivalent structures. Moreover, unless the term “means” is explicitly recited in a limitation of the claims, such limitation is not intended to be interpreted under 35 U.S.C. §112, sixth paragraph.

What is claimed is:

1. A method of manufacturing an organic electroluminescent display device, comprising:
  - forming transistors on a substrate;
  - forming an insulating layer on the transistors;
  - forming a lower electrode on the insulating layer, the lower electrode being coupled to a source or a drain of each of the transistors
  - forming a bank layer on the lower electrode, the bank layer having openings to expose part of the lower electrode;

forming a bus electrode on the bank layer;  
 forming an organic light-emitting layer to cover the lower electrode, the bank layer, and the bus electrode;  
 patterning the organic light-emitting layer using a laser, thereby exposing at least part of the bus electrode placed on the bank layer; and  
 forming an upper electrode on the organic light-emitting layer so that the upper electrode comes into contact with the exposed bus electrode.

2. The method of manufacturing an organic electroluminescent display device according to claim 1, wherein the step of forming the bus electrode further comprises forming the bus electrode in a shape of a mesh or stripes.

3. The method of manufacturing an organic electroluminescent display device according to claim 1, wherein the upper electrode has a single layer made of at least one of metal, metal oxide, and an organic conductive material or a multilayer made of at least two of metal, metal oxide, and an organic conductive material.

4. A method of manufacturing an organic electroluminescent display device, comprising:

forming transistors on a substrate;  
 forming an insulating layer on the transistors;  
 forming a lower electrode on the insulating layer, the lower electrode being coupled to a source or a drain of each of the transistors;  
 forming a bus electrode separated from the lower electrode and disposed on the insulating layer;  
 forming a bank layer on the lower electrode, the bank layer having first openings to expose part of the lower electrode and second openings to expose at least part of the bus electrode;  
 forming an organic light-emitting layer to cover the lower electrode, the bank layer, and the bus electrode;  
 patterning the organic light-emitting layer using a laser, thereby exposing at least part of the bus electrode on the bank layer; and  
 forming an upper electrode on the organic light-emitting layer so that the upper electrode comes into contact with the exposed bus electrode.

5. The method of manufacturing an organic electroluminescent display device according to claim 4, wherein the step of forming the bus electrode further comprises forming the bus electrode in a shape of a mesh or stripes.

6. The method of manufacturing an organic electroluminescent display device according to claim 4, wherein the upper electrode has a single layer made of at least one of metal, metal oxide, and an organic conductive material or a multilayer made of at least two of metal, metal oxide, and an organic conductive material.

7. An organic electroluminescent display device, comprising:

transistors formed on a substrate;  
 an insulating layer on the transistors;  
 a lower electrode formed on the insulating layer and coupled to a source or a drain of each of the transistors;  
 a bank layer having openings to expose part of the lower electrode;  
 a bus electrode formed on the bank layer;  
 an organic light-emitting layer formed to cover the lower electrode, the bank layer, and the bus electrode and patterned to expose at least part of the bus electrode; and  
 an upper electrode formed on the organic light-emitting layer and configured to come into contact with the exposed bus electrode.

8. The organic electroluminescent display device according to claim 7, wherein the bus electrode is in a shape of a mesh or stripes.

9. An organic electroluminescent display device, comprising:

transistors formed on a substrate;  
 an insulating layer on the transistors;  
 a lower electrode formed on the insulating layer and coupled to a source or a drain of each of the transistors;  
 a bus electrode formed on the insulating layer and separated from the lower electrode;  
 a bank layer having first openings to expose part of the lower electrode and second opening to expose at least part of the bus electrode;  
 an organic light-emitting layer formed to cover the lower electrode, the bank layer, and the bus electrode and patterned to expose at least part of the bus electrode; and  
 an upper electrode formed on the organic light-emitting layer and configured to come into contact with the exposed bus electrode.

10. The organic electroluminescent display device according to claim 9, wherein the bus electrode is in a shape of a mesh or stripes.

\* \* \* \* \*

专利名称(译)	有机电致发光显示装置及其制造方法		
公开(公告)号	<a href="#">US20100283071A1</a>	公开(公告)日	2010-11-11
申请号	US12/608648	申请日	2009-10-29
[标]申请(专利权)人(译)	乐金显示有限公司		
申请(专利权)人(译)	LG DISPLAY CO. , LTD.		
当前申请(专利权)人(译)	LG DISPLAY CO. , LTD.		
[标]发明人	LI FENGJIN LEE JAEYOUNG YOO TAEYEON		
发明人	LI, FENGJIN LEE, JAEYOUNG YOO, TAEYEON		
IPC分类号	H01L51/52 H01L33/00		
CPC分类号	H01L27/3244 H01L51/56 H01L51/5203 H01L51/5228		
优先权	1020090039313 2009-05-06 KR		
其他公开文献	US8003417		
外部链接	<a href="#">Espacenet</a> <a href="#">USPTO</a>		

摘要(译)

制造有机电致发光显示装置的方法可包括在基板上形成晶体管，在绝缘层上形成下电极，在晶体管上形成绝缘层，下电极耦合到每个晶体管的源极或漏极在下电极上形成堤层，堤层具有开口以暴露下电极的一部分，在堤层上形成汇流电极，形成覆盖下电极的有机发光层，堤层和汇流电极，使用激光对有机发光层进行图案化，从而暴露放置在堤层上的汇流电极，并在有机发光层上形成上电极，使得上电极与暴露的总线接触电极。

